

PRZEKRÓJ C-C
SKALA 1

PRZEKRÓJ A-A
SKALA 1 / 4

Rys. 1

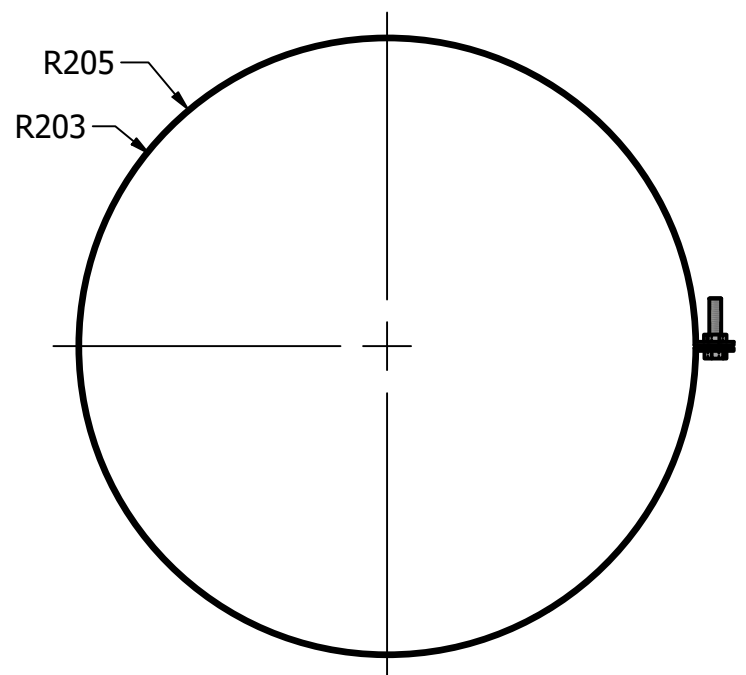
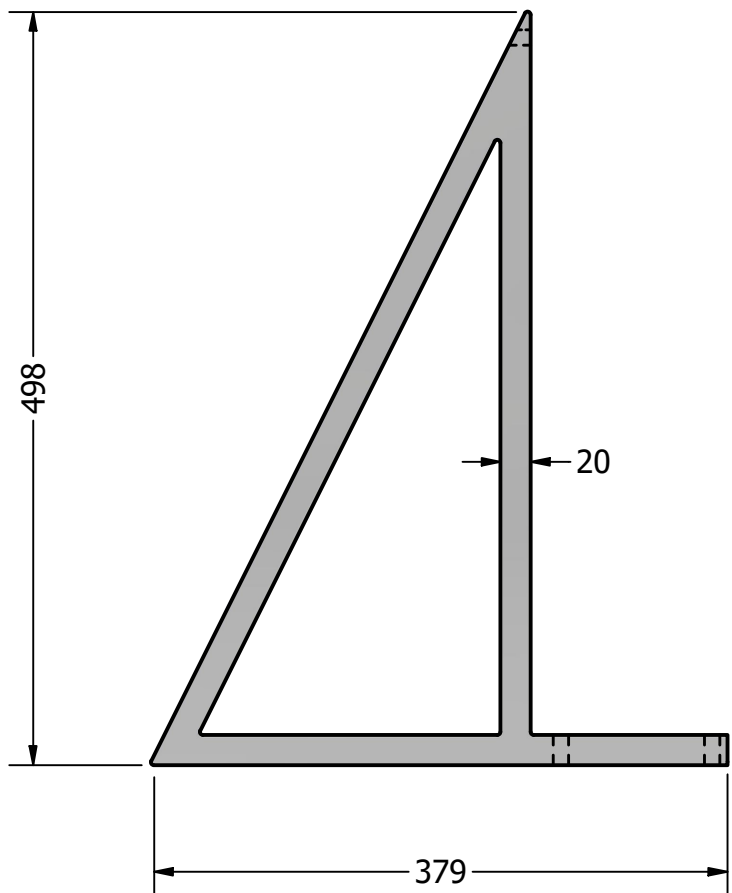
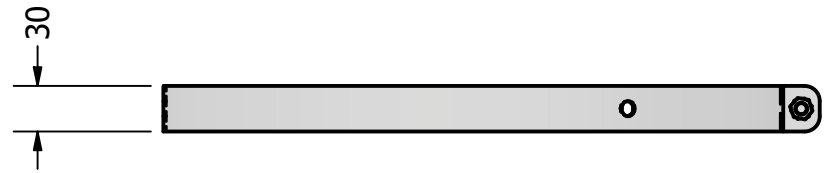
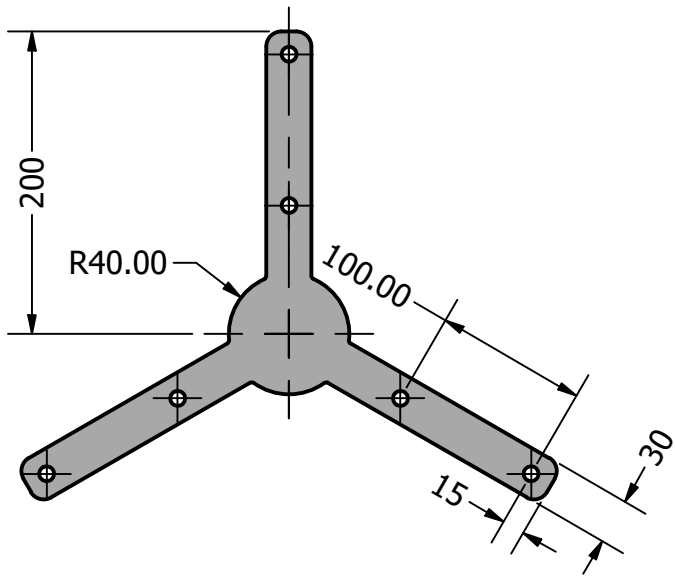
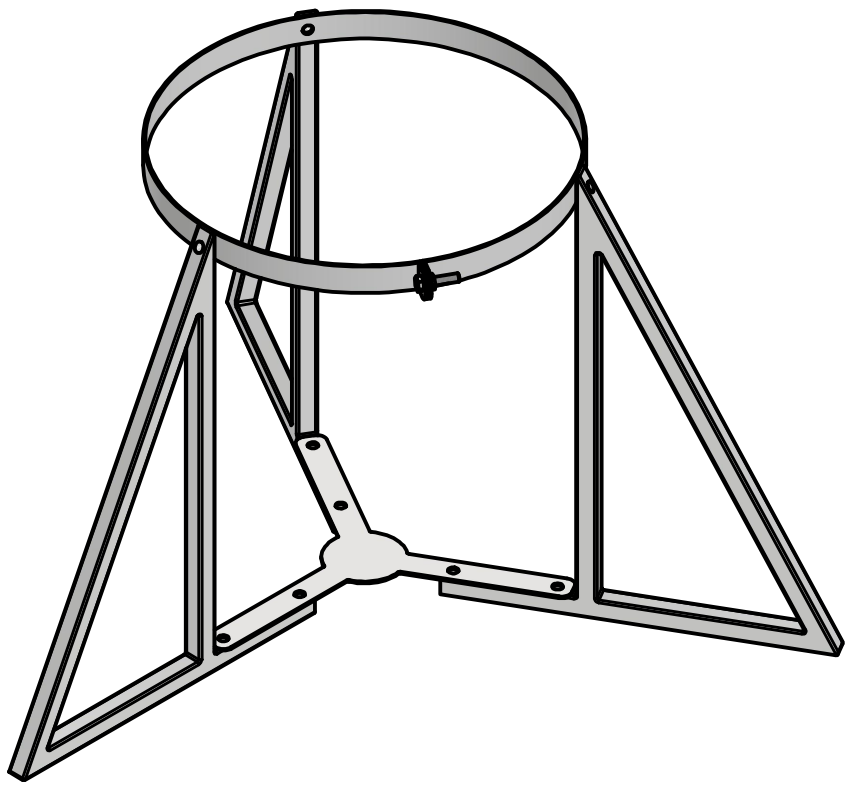

Rys. 2

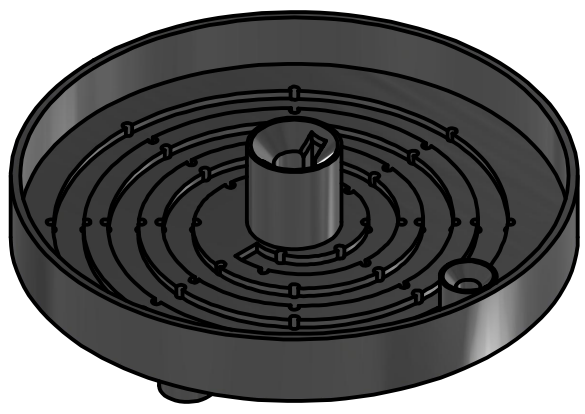

Brzeg dna wykonany z rury PMMA o wysokości 30mm

Dno wykonane z płyty PMMA o grubości 10mm

Kanał dla elektrody grafitowej wyfrezowany na głębokość 5mm w płycie dna. Maksymalna długość elektrody to 1900mm

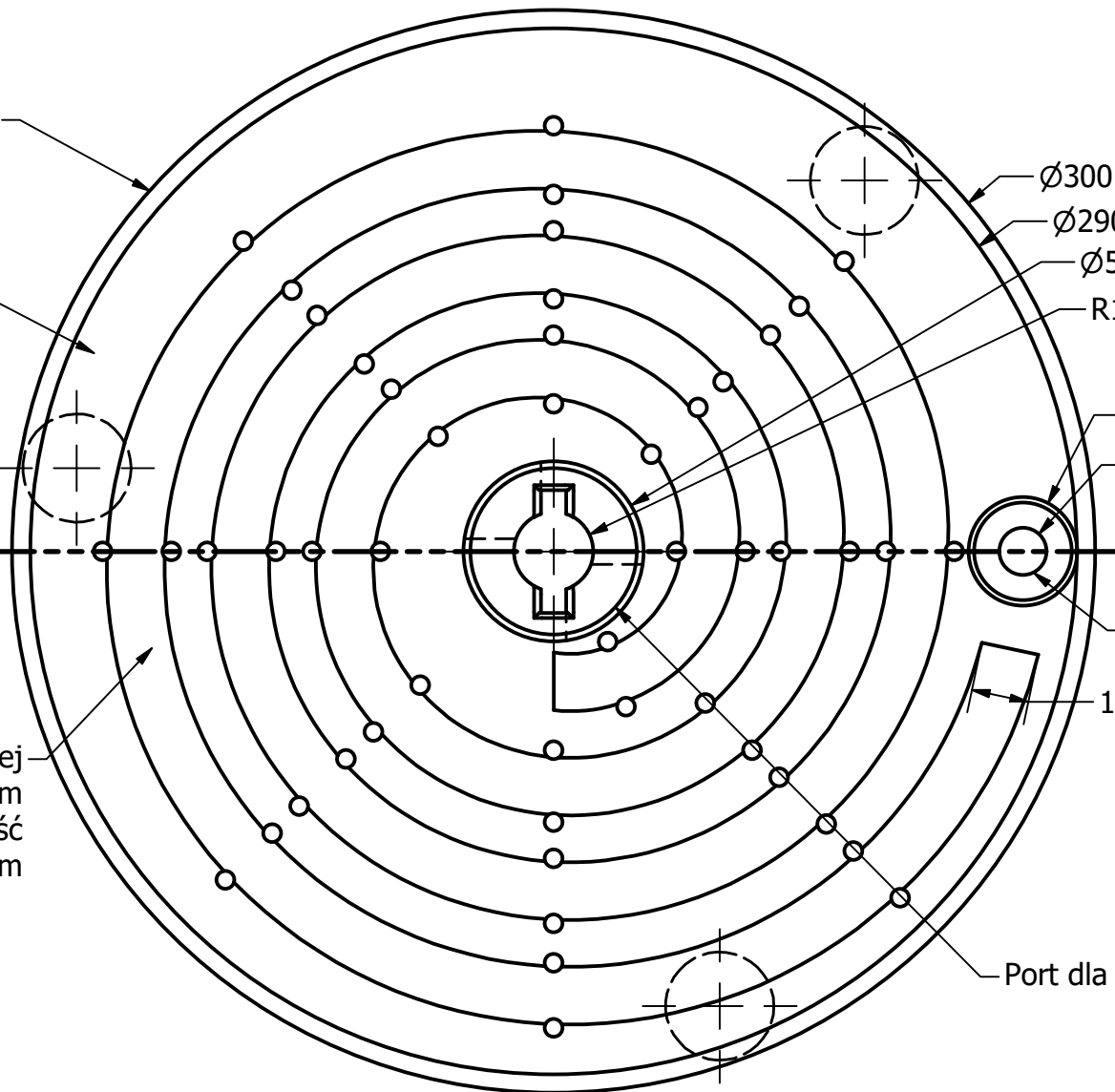

Ø300
Ø290
Ø50
R11

Ø30
Ø13

Port dla statywu elektrod pomiarowych

16

Port dla pręta serwisowego

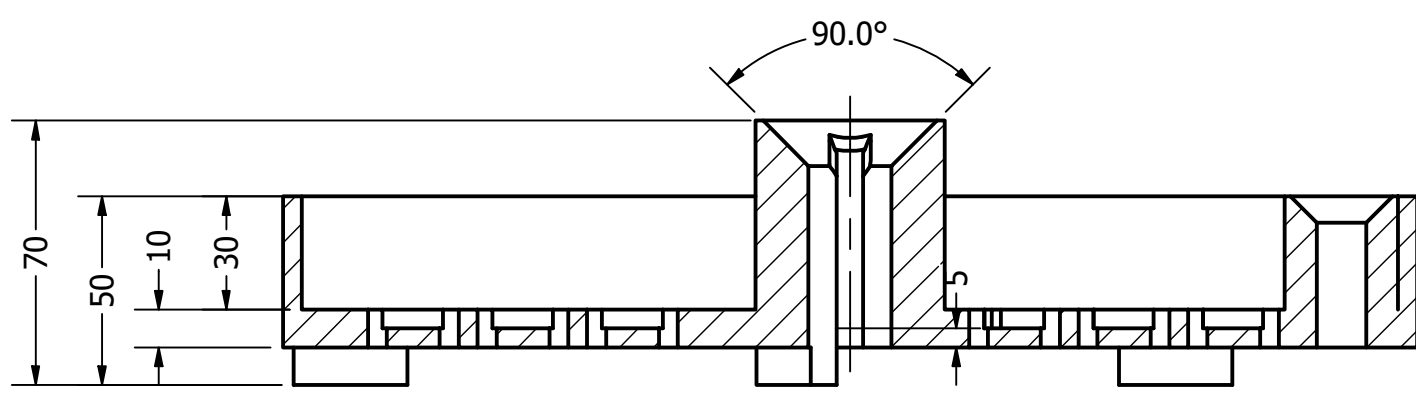

PRZEKRÓJ B-B
SKALA 0,5

Rys. 3

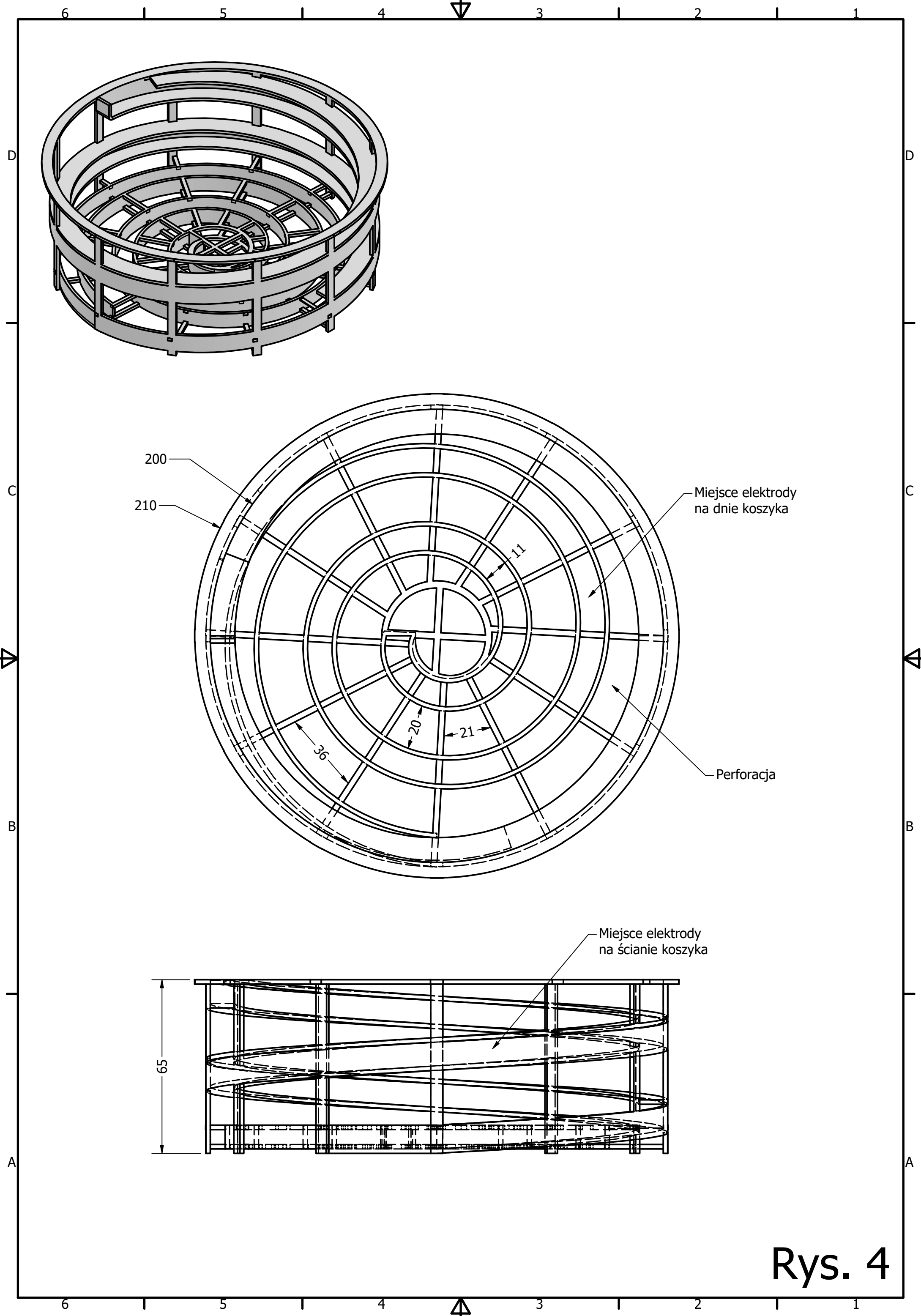

Rys. 4

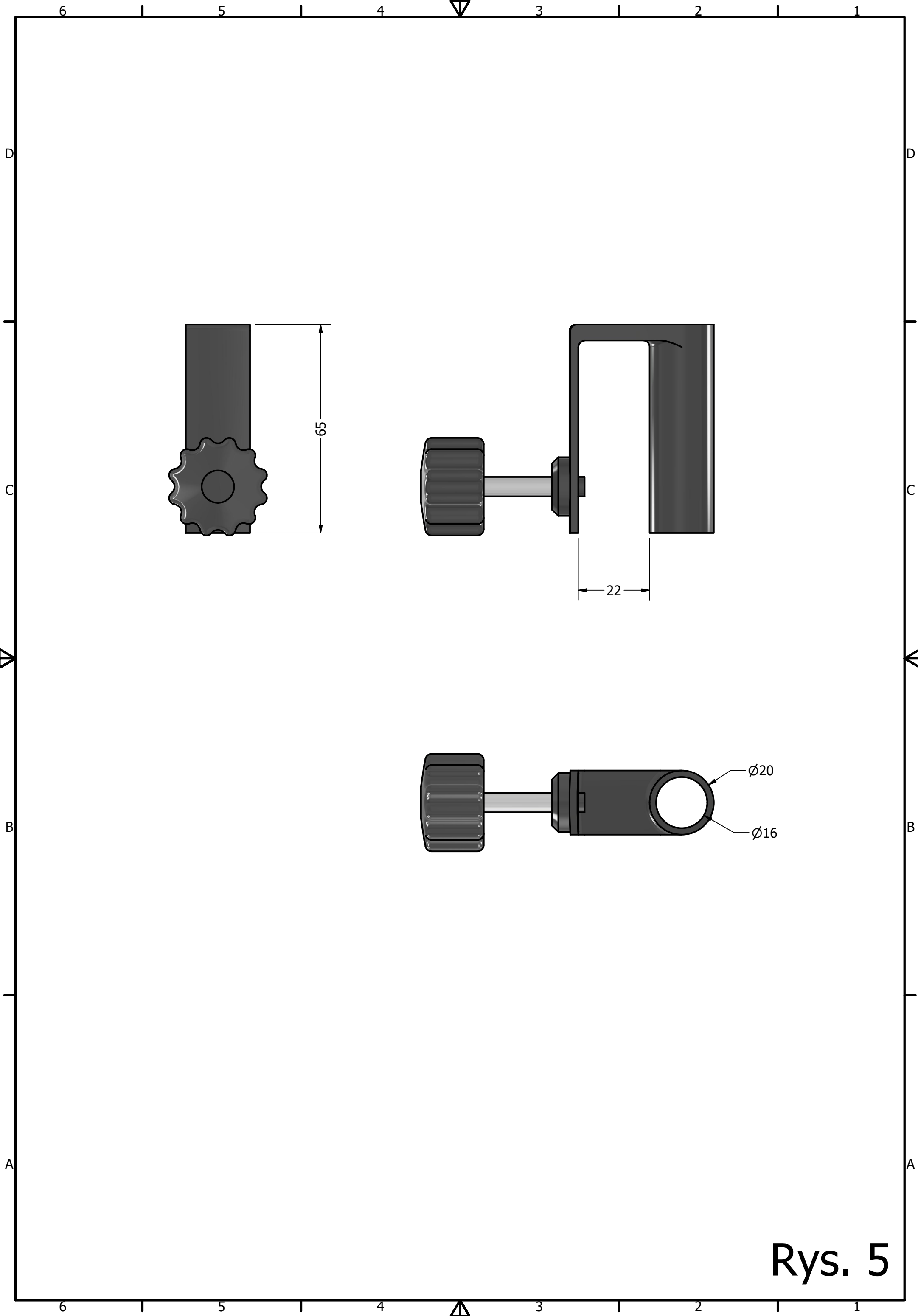

Rys. 5